



MOTO GUZZI V85 TT 2019 >

OVAL CARBON CAP

ELENCO PARTI / PARTS LIST

#	QTÀ / QTY	DESCRIZIONE / DESCRIPTION	CODICE / CODE
1	1	DB killer / DB killer	50.DK.067.0
2	1	Tappo in gomma / Rubber stopper	50.73.266.1
3	1	Silenziatore / Muffler	OVAL CARBON CAP 400
4	1	Vite M8x45 / Screw M8x45	50.73.602.1
5	1	Rondella in alluminio nera / Black aluminium washer	50.73.221.1
6	1	Dado M8 flangiato / Flanged nut M8	50.73.393.1
7	2	Vite M8 x 16 / Screw M8 x 16	50.73.098.1
8	2	Rondella di sicurezza / Safety washer	50.73.604.1
9	1	Staffa / Bracket	50.SS.1183.0
10	1	Molla media / Mid-size spring	50.73.359.1
11	1	Tube in gomma per molla / Rubber pipe for spring	50.73.210.1
12	2	Fascetta con bussola / Pipe clamp with bush	50.73.466.0
13	1	Carter / Cover	50.CR.046.1
14	2	Rondella M5 / Washer M5	50.73.351.1
15	2	Vite M5 x 8 / Screw M5 x 8	50.73.459.1
16	1	Tube di raccordo / Link pipe	9773M013SE
17	1	Fascetta Ø 56/59 mm / Pipe clamp Ø 56/59 mm	50.FA.009.1

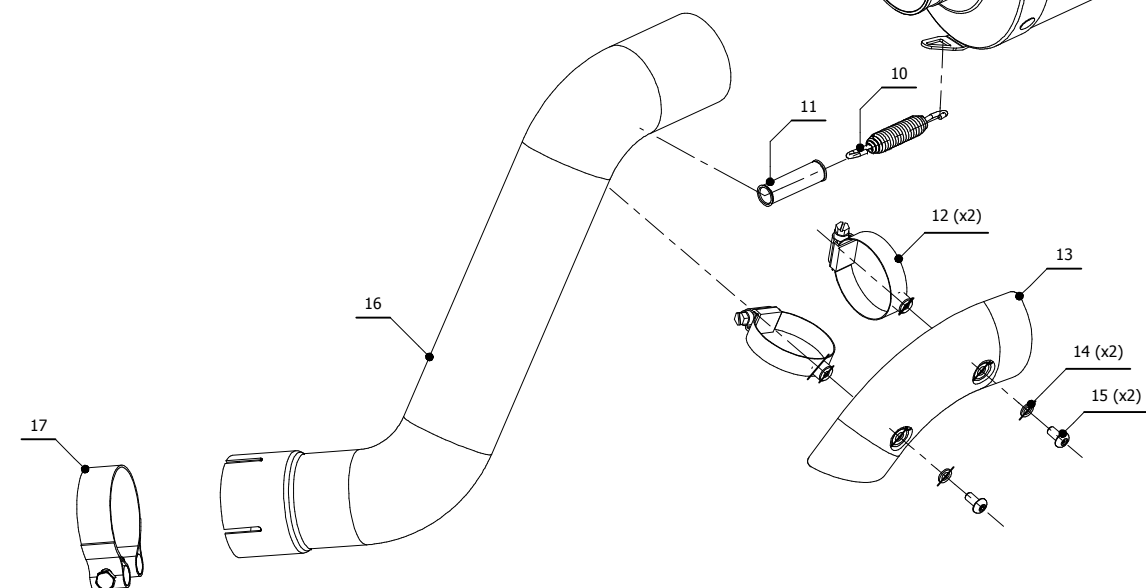
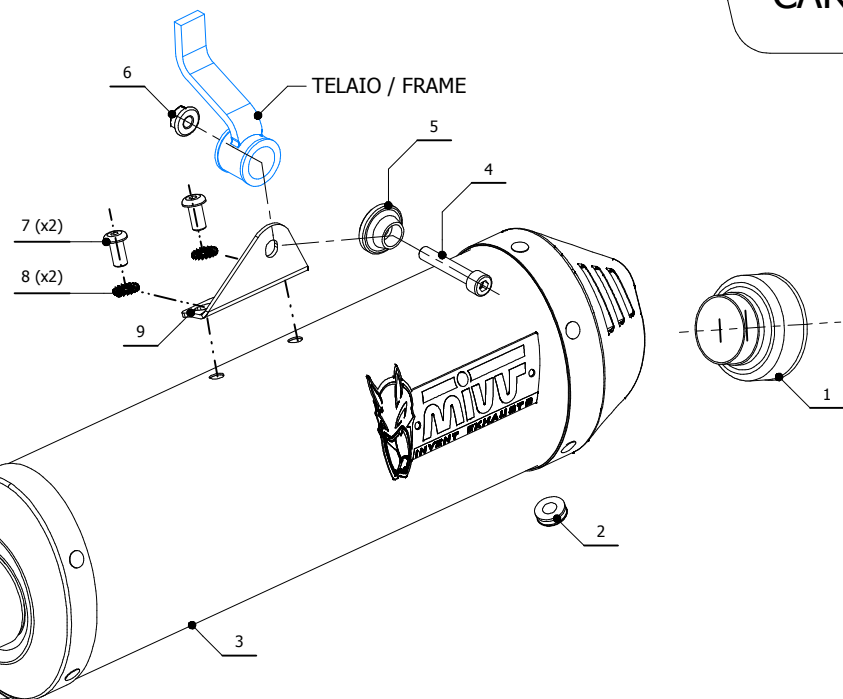

APPLICAZIONI / APPLICATIONS

CODICE / CODE	SILENZIATORE / MUFFLER	TUBO / PIPE	FASCETTA / CLAMP
M.013.LEC	CARBONIO (COPPA CARBONIO) / CARBON (CARBON CAP)	INOX / ST.STEEL	///
M.013.LNC	TITANIO (COPPA CARBONIO) / TITANIUM (CARBON CAP)		